

CB1E 齿轮泵 GROUP1 EUROPEAN STYLE GEAR PUMPS

简介 General Description

CB1E 齿轮泵系高压小排量齿轮油泵，由一对高强度齿轮、轴套、泵体、前盖、后盖 等主要部件组成，轴向间隙由高精度浮动轴套自动补偿，使得 CB1E 齿轮泵具有高的机械效率和容积效率，该泵噪音低、可靠性高，广泛应用于卡车液压系统，举升和传送机械，矿山机械，农业机械等。

The CB1E gear pump consists of a gear pair supported by two aluminum bearing blocks, a housing, front cover and rear cover. The axial clearance can be automatically compensated by the bearing blocks. The CB1E pump features are simple structure, high mechanical and volumetric efficiency, low noise level as well as high reliability. It is widely used in the hydraulic system of truck, lift and transport machinery, mining machine, and agriculture, etc.



型谱 Order Code

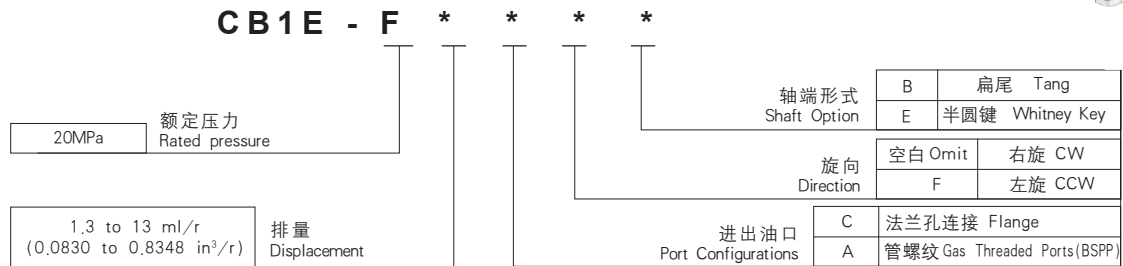

外形尺寸图 Outline Dimension

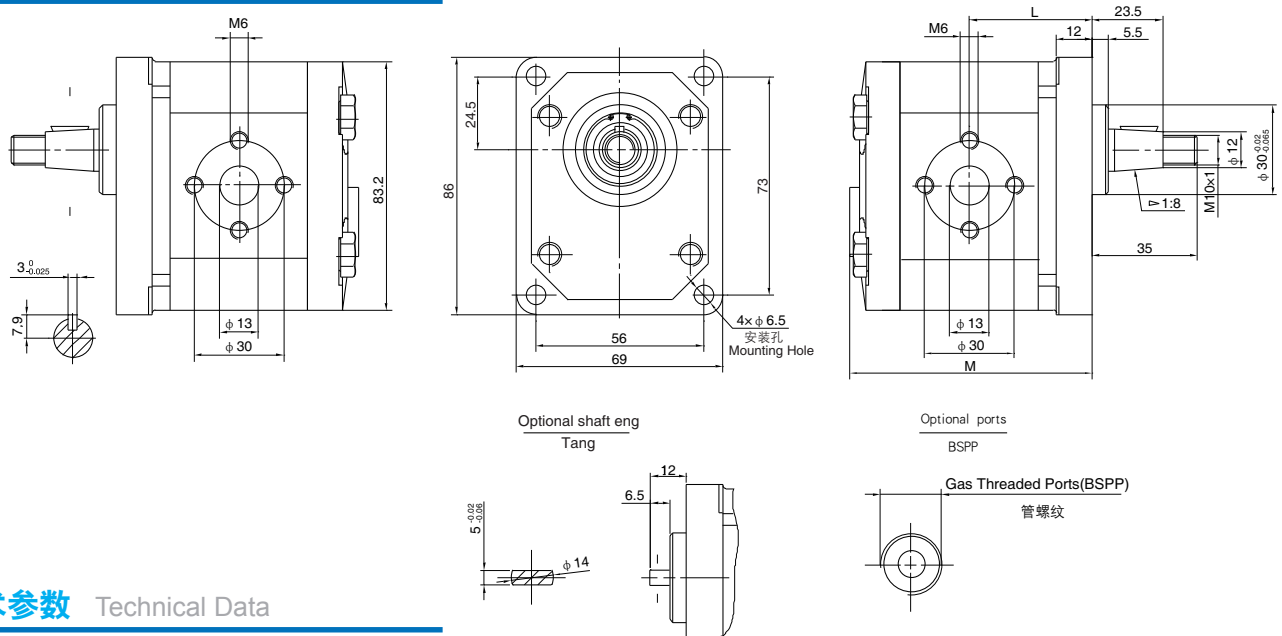

技术参数 Technical Data

| Model 型号 | Displacement 排量 mL/r(in ³ /r) | 压力 Pressure | | | 转速 Speed | | 尺寸 Dimension | | | | | |
|-------------|--|-------------|-----|-----|----------|------|--------------|------|-----------|------------|-----------|------------|
| | | P1 | P2 | P3 | Rated | Max | L | M | G 螺纹型进油口 | | 法兰型进油口 | |
| | | MPa | MPa | MPa | RPM | RPM | mm | mm | 进油口 Inlet | 出油口 Outlet | 进油口 Inlet | 出油口 Outlet |
| CB1E-F1.3* | 1.36 (0.083) | 20 | 25 | 28 | 2000 | 4000 | 40 | 79 | G1/2 | G3/8 | φ 13 | φ 13 |
| CB1E-F2 * | 2.05 (0.125) | | | | | | 41 | 81 | | | | |
| CB1E-F2.7* | 2.74 (0.167) | | | | | | 42 | 83 | | | | |
| CB1E-F3.2 * | 3.42 (0.209) | | | | | | 43 | 85 | | | | |
| CB1E-F4 * | 4.10 (0.250) | | | | | | 44 | 87 | | | | |
| CB1E-F5 * | 5.13 (0.313) | | | | | | 45.5 | 90 | | | | |
| CB1E-F6 * | 6.16 (0.376) | | | | | | 47 | 93 | | | | |
| CB1E-F7.5 * | 7.52 (0.459) | 18 | 20 | 22 | 3500 | 49 | 97 | G1/2 | G1/2 | φ 13 | φ 13 | |
| CB1E-F9 * | 9.23 (0.563) | | | | | | | | | | | 3000 |
| CB1E-F10 * | 10.95 (0.668) | 15 | 18 | 20 | 2500 | 54 | 107 | G1/2 | G1/2 | φ 13 | φ 13 | |
| CB1E-F13 * | 13.68 (0.835) | | | | | | | | | | | 2000 |